

## NEW VEHICLES AND PARTS.

### The Pope-Toledo Model XV.

The Pope Motor Car Company, of Toledo, Ohio, have this year departed materially from the general line of design followed by them for several years past. Lightness of construction without sacrifice in strength has, however, been one of the prime objects of the designer, the same as in former years, and no reasonable expense is spared to eliminate all dead weight, even in the smallest of the parts. Chrome-nickel steel is extensively used in gears, levers, links, etc., and D. W. F. ball bearings are used throughout.

#### GENERAL SPECIFICATIONS.

The car is designed to carry seven passengers; it is equipped with a 50 horse power motor, four speeds and reverse sliding pinion change gear, and is side chain driven. The wheel base is 115 inches and the tread 54 inches. Wheels are 36 inches diameter, the front shod with  $3\frac{1}{2}$  and the rear with  $4\frac{1}{2}$  inch tires.

#### THE MOTOR.

The four cylinder, vertical motor has a bore of  $4\frac{7}{8}$  inches and a stroke of  $5\frac{1}{4}$  inches. Cylinders are cast in pairs, with integral heads and integral jackets to a point just below the compression space. The remainder of the jackets is sheet copper, which is joined to the cylinder by having lead caulked tightly over the edges, which fit into dovetail grooves in the cylinder wall. On the bottom of the cylinders are two extremely long snap rings fitting bored holes in the crank case. Six studs with castle nuts secure each cylinder casting to the crank case.

The valves are in the head, and the inlet and exhaust valves for each cylinder are controlled from a double cam through a single walking beam and push rod. The cam rotates left handedly, as seen in the sectional view of the engine. The point raises

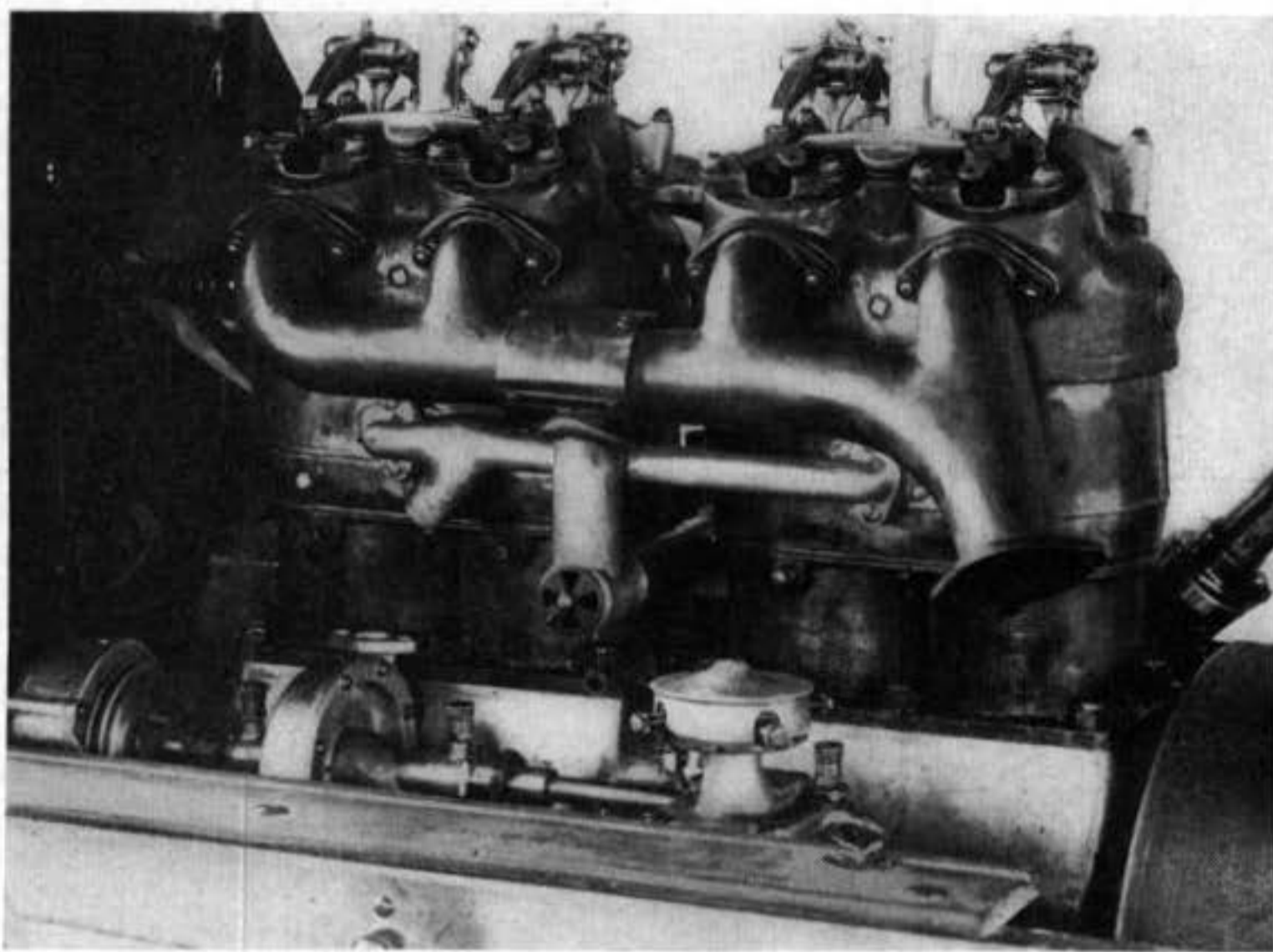

LEFT HAND SIDE OF POPE-TOLEDO MODEL XV ENGINE.

the tapped rod, which opens the exhaust valve by means of a walking beam. When the flat portion of the cam comes under the roller the spring surrounding the tapped rod forces the rod downward, thus opening the inlet valve, which is normally held on its seat by a coiled spring around its stem. The exhaust valves for each cylinder are held to their seats by a helical spring in a pocket midway between them, which pushes a walking beam with forked ends upward. (See side view of engine.) The cam shaft runs in plain bearings and is driven by spiral gears at the front end.

The crank shaft is forged from a block of chrome-nickel steel, and runs in three D. W. F. bearings. The pins are 1 15-16x3 inches. Connecting rods are drop forged, and are  $11\frac{1}{4}$  inches, centre to centre. The caps are shouldered to preserve alignment

with the rod. Bronze bushings are used. The piston pin is  $1\frac{1}{8}$  inches in diameter, and is secured by a single large set screw. The pistons are long, have flat tops and nine rings each, in unusually narrow and deep grooves. The ring below the pin is of the usual rectangular section; in each of the four upper grooves are two triangular section rings, the outer of uniform section and the inner eccentric. The crank case is of aluminum, split horizontally. Semi-circular steel rings are cast in place to act as seats for the D. W. F. bearings.

Cooling water is circulated by a gear driven centrifugal pump on the left side of the engine. The familiar Toledo planetic type of radiator is used. The capacity of the cooling system is  $4\frac{1}{2}$  gallons. An eight bladed, sheet metal fan is used, belt driven from the pump shaft. The carburetor,

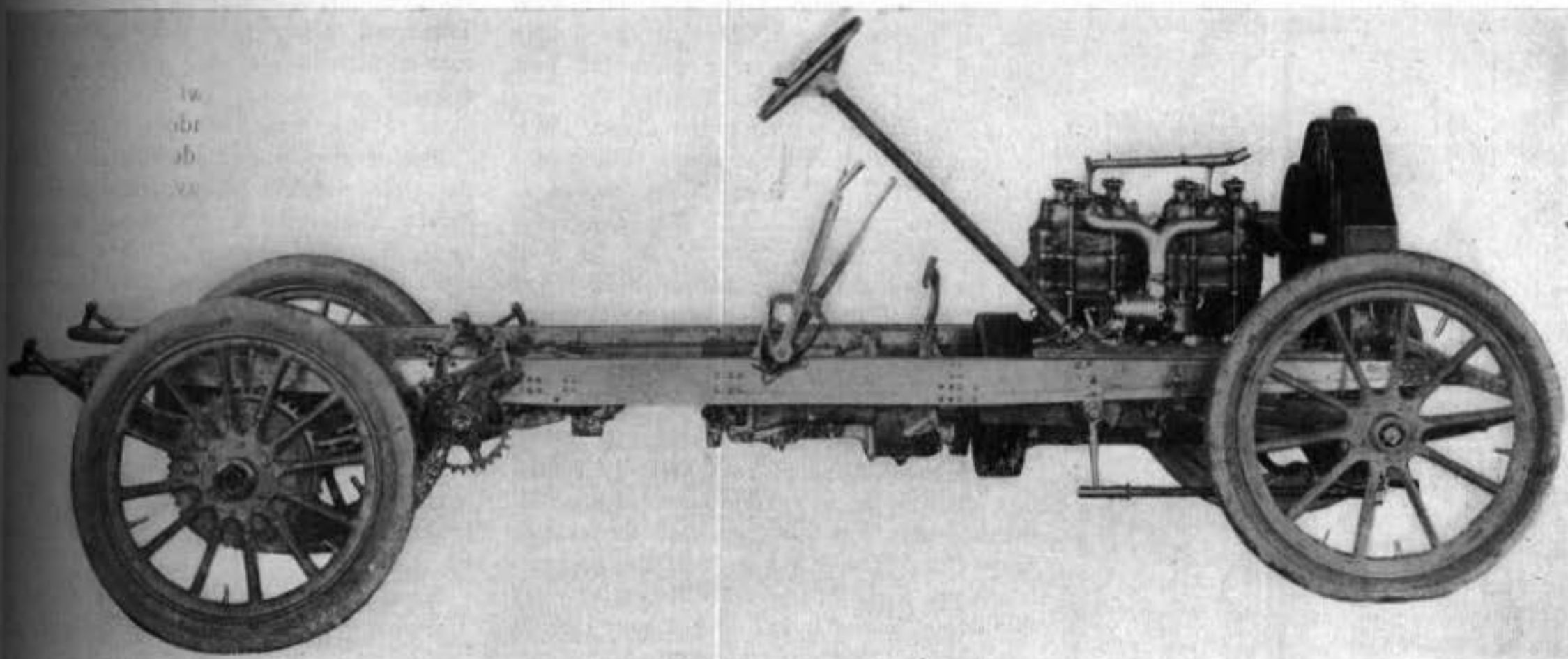

SIDE VIEW OF POPE-TOLEDO TYPE XV CHASSIS.

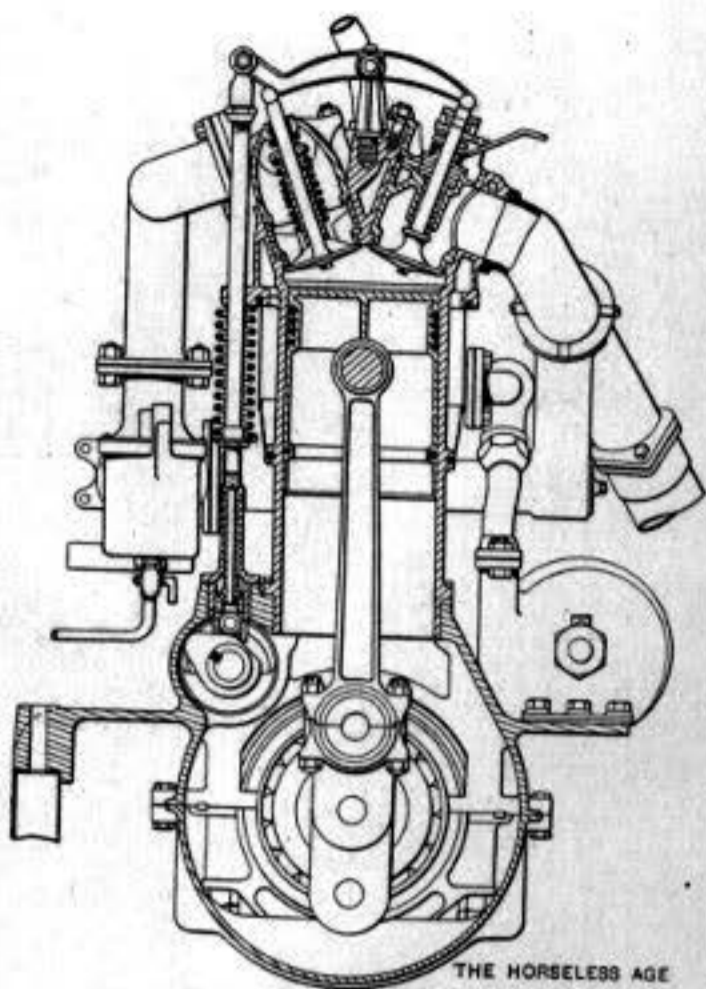

SECTION OF ENGINE.

which is similar to the 1906 model, is located well down on the left side. Hot air is supplied by a jacket around the exhaust manifold, and its temperature may be regulated by a damper in the elbow below.

Jump spark ignition is used, current being supplied by a gear driven Bosch magneto and batteries. The roller contact timer is located on a vertical shaft, driven from the pump shaft by spiral gears. Lubrication is secured by a Lunkenheimer mechanical oiler on the dash, belt driven from the cam shaft. A large oil tank is located under the foot-board, and the oiler may be filled from this by a hand pump. Gasoline is carried in a double cylindrical tank at the rear, and is fed by pressure to a small auxiliary tank, which supplies the carburetor.

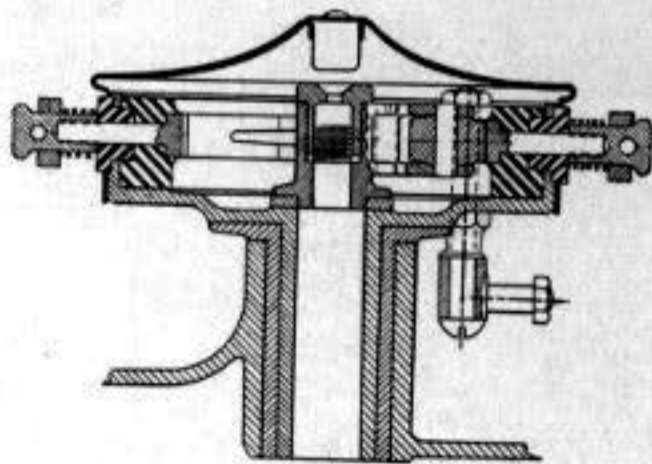
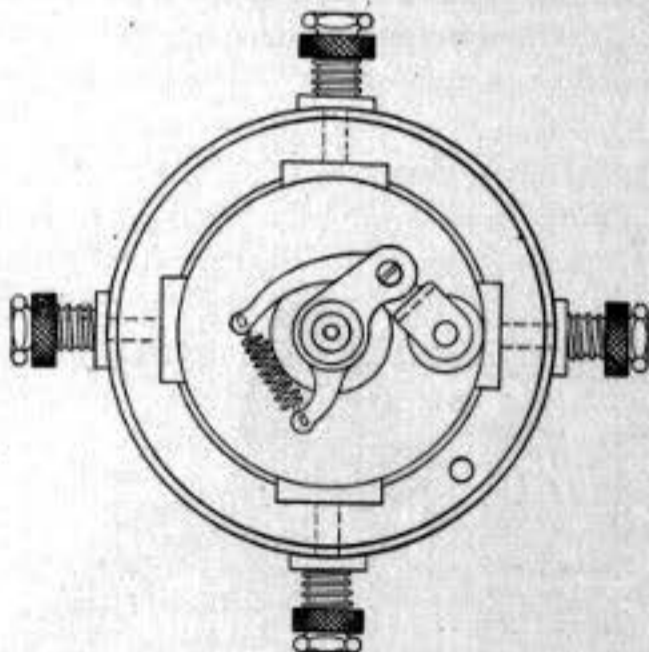
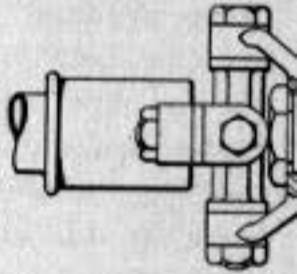

THE TIMER.

The flywheel is secured by shouldered studs to a flange integral with the crank shaft. To the flywheel is connected the forward portion of the universal coupling to the transmission.

#### CLUTCH AND CHANGE SPEED GEAR.

A multiple disc clutch is used. To the rear end of the hollow clutch shaft is fastened a drum, to which are keyed the plates of the smaller set. The larger plates are keyed to a manganese bronze drum secured to a disc keyed to a short shaft formed integral with the clutch pinion. Between these plates are small helical springs. The clutch is applied by helical springs secured to studs in the plate at the engine end. The dimensions are unusually large for a clutch of this type, being 10 3-16 inches outside working diameter, 5 9-16 inside working diameter, while the total friction surface is over 2,000 square inches. The discs are of steel, about one-sixteenth inch thick, ground on both sides.

#### RUNNING GEAR DETAILS.

The rear wheels have twelve spokes, the front ten, of unusual width lengthwise of the axle. Contrary to the usual practice, both inner and outer flanges are integral with the hub barrel. Both front and rear axles are chrome-nickel steel, I section. Steering pivots are of the inverted Lemoine type. Both pivots and wheels are fitted with D. W. F. bearings.

An inverted U section is still used for the side members of the frame. The metal is folded up against the outside of the U for a short distance at the bottom of the section, giving four thicknesses under tension. The motor is carried on a sub-frame, while the change speed gear and driving gear housing are carried on cross members. By removing the radiator the motor may be slid forward and removed from the frame.

Semi-elliptic springs are used both in front and rear. They are 2 inches wide



5 model, is lo-  
side. Hot air  
and the exhaust  
may be regu-  
low below.  
ed, current be-  
Bosch magneto  
tact timer is lo-

nder the foot-  
filled from this  
is carried in a  
e rear, and is  
auxiliary tank,

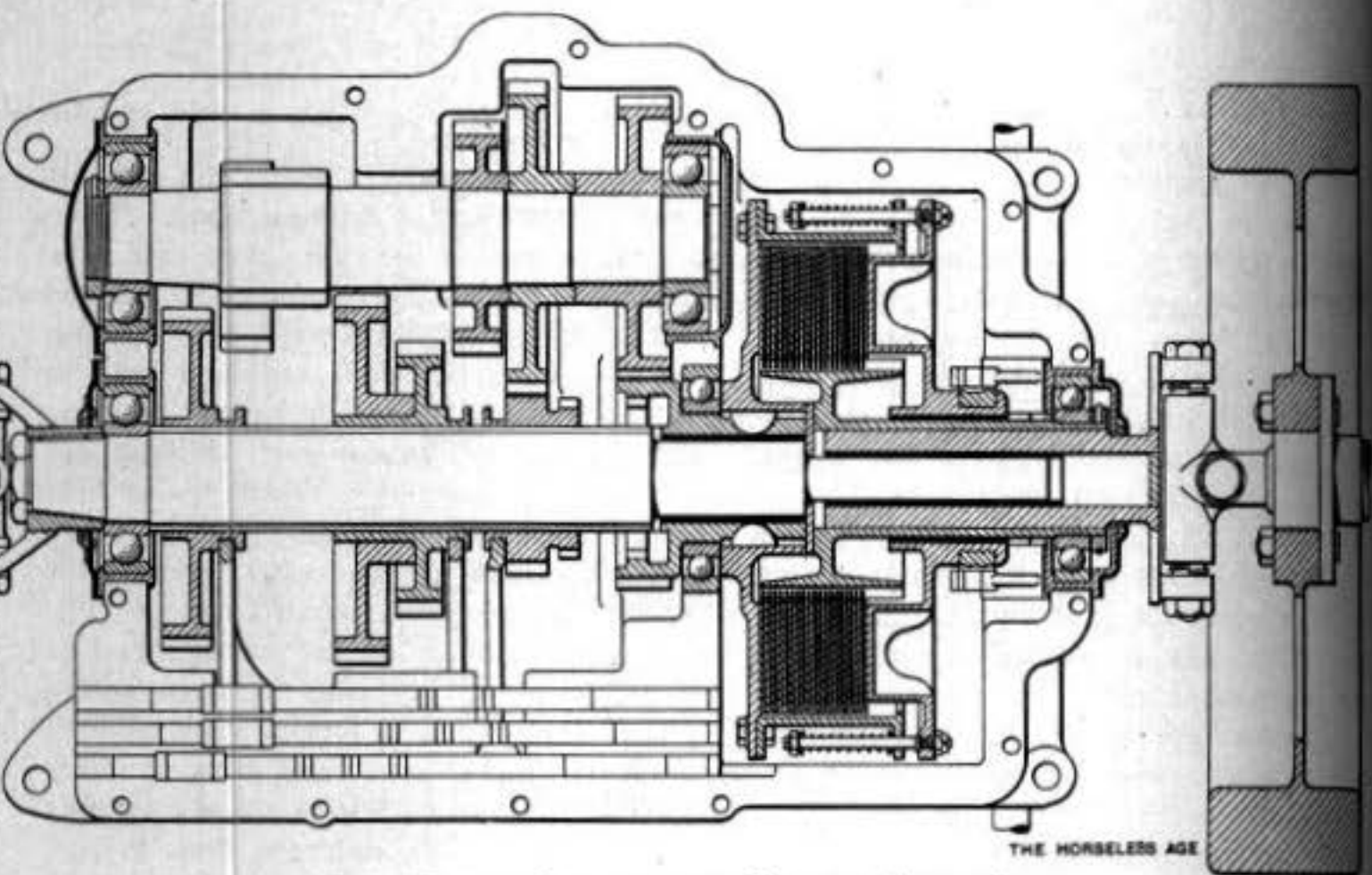

POPE-TOLEDO CLUTCH AND CHANGE SPEED GEAR.

The clutch pinion is cut also with teeth for an internal clutch. Moving the double sliding pinion to the rear gives the first speed; moving it forward gives the second. The third, which is the direct drive, is secured by moving the single sliding pinion forward. As shown, the gears are in the fourth speed position. The reserve is obtained by sliding forward the gear at the rear end of the first motion shaft. Gear shifting is on the selective system. A finger attached to the hand lever shaft slides rectangular section shifter rods at the right. The gears are 6 pitch, of specially treated chrome-nickel steel.

The bevel driving gears and differential are enclosed in a separate case, with a universal joint between them and the change gear case. The inner ends of the countershaft are flanged, and the differential gears bolted to these flanges. Eight spur pinions are used. The front sprockets are chrome-nickel steel, and the D. W. F. bearings are carried close to the chain line.

and have many leaves to give soft action. The front springs have drop links on their rear ends, while the rear springs are linked at each end.

#### BRAKES, STEERING AND CONTROL.

The service brake, which is operated by the right pedal, acts on a drum upon the driving shaft between the change gear case and differential housing. It is of the band type, 9 inches in diameter, and anchored to the side member of the frame. The emergency brakes, which are of the toggle joint, expanding type, act on drums integral with the wheel sprockets. Their friction surfaces are 14 inches in diameter by 2 1/4 inches face. They are fully enclosed and anchored to the chain struts. Both sets of brakes are equalized, and are interconnected with the clutch.

Steering is through worm and sector. The post is considerably more inclined than in former models. Spark and throttle are controlled by levers moving over stationary ratchets above the wheel. The inner hand

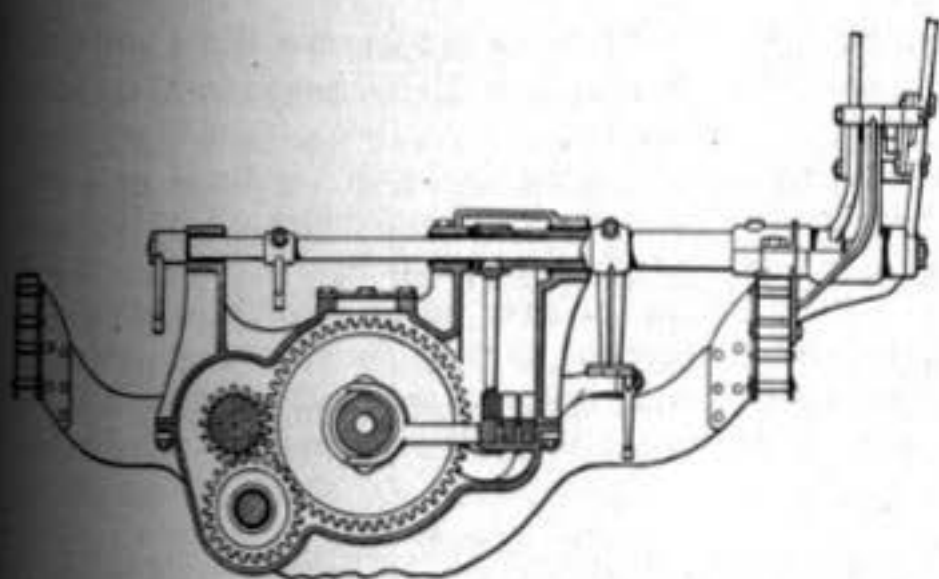

HAND BRAKE SHAFT AND GEAR SHIPPER ASSEMBLY.

lever shifts the gears and is fitted with the usual pawl to prevent entering the reverse slot accidentally. The outer hand lever is pulled back to apply the emergency brakes. For convenience in starting the exhaust valve guides are made with a square thread on the outside, and fitted with levers which are connected together by rods. From the front cylinder a rod leads through a hole in the radiator, and pulling the handle on its end rotates all four guides and opens the exhaust valves, thus relieving compression. Another handle near the bottom of

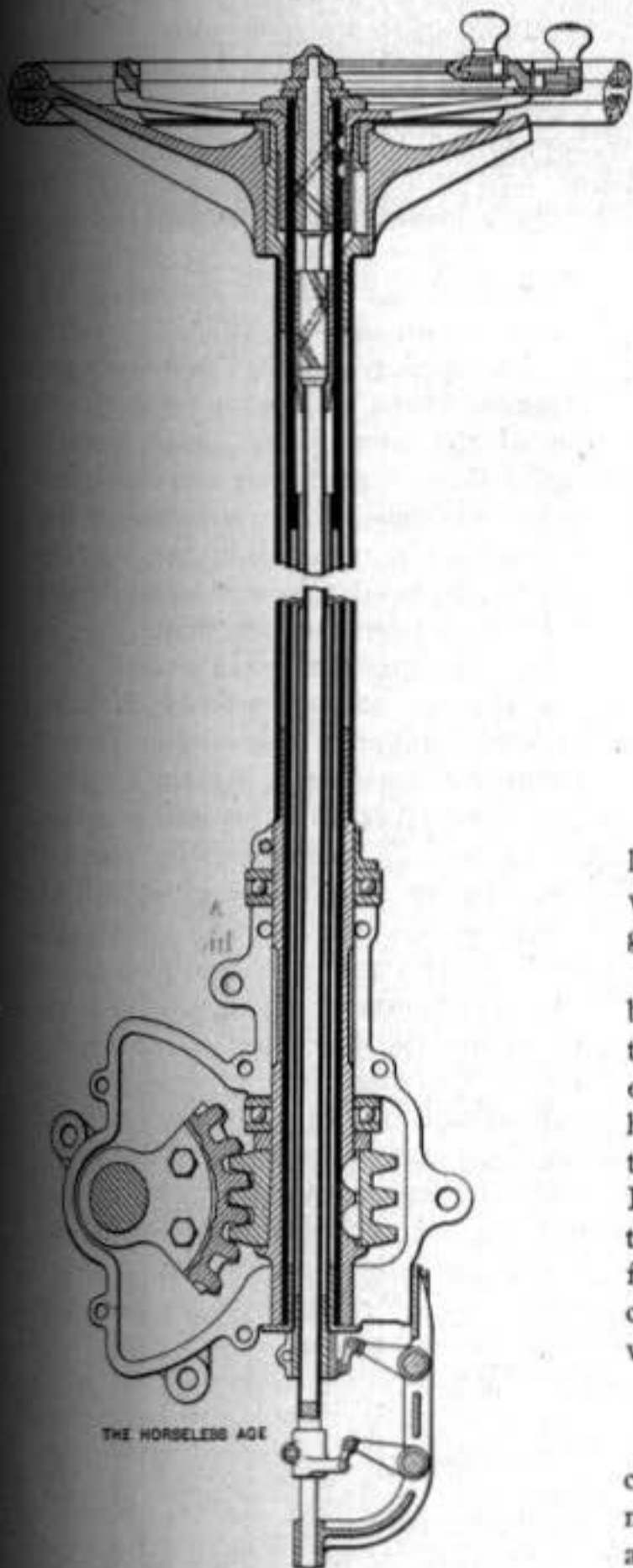

POPE-TOLEDO STEERING GEAR.

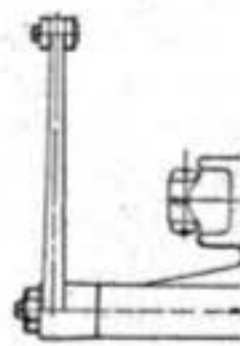
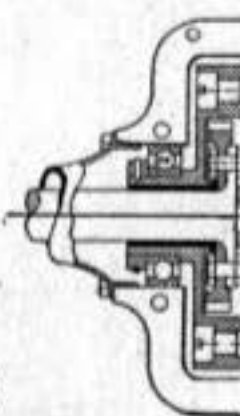

long character will be seen from guards are also The equipment bolens searchlight tail lamp, accessories of equipment of horn. All parts, equipment Pope factory. that on account force and material chrome-nickel will be limited

George Bor claims to have mobile engine are very rapid inder.

THE HORSELESS AGE

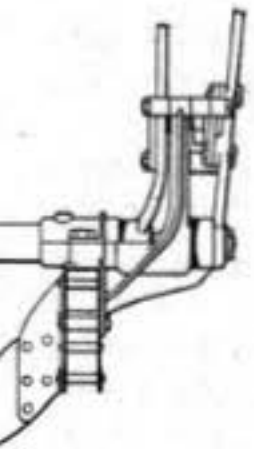

the radiator connects with a "tickler" on the carburetor.

BODY, HOOD, MUD GUARDS, ETC.

The body is of pressed steel, and the tonneau seat is so wide that it is said to accommodate four adults of average size without discomfort, although only intended for three. Two folding seats are provided, making room for seven passengers in all. The hood is of aluminum, and has been changed from the shape so

ASSEMBLY.

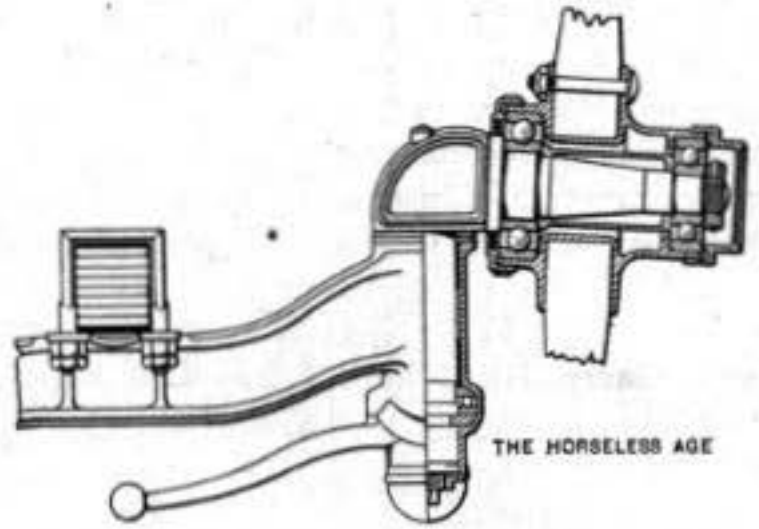

THE HORSELESS AGE

POPE-TOLEDO FRONT AXLE END.

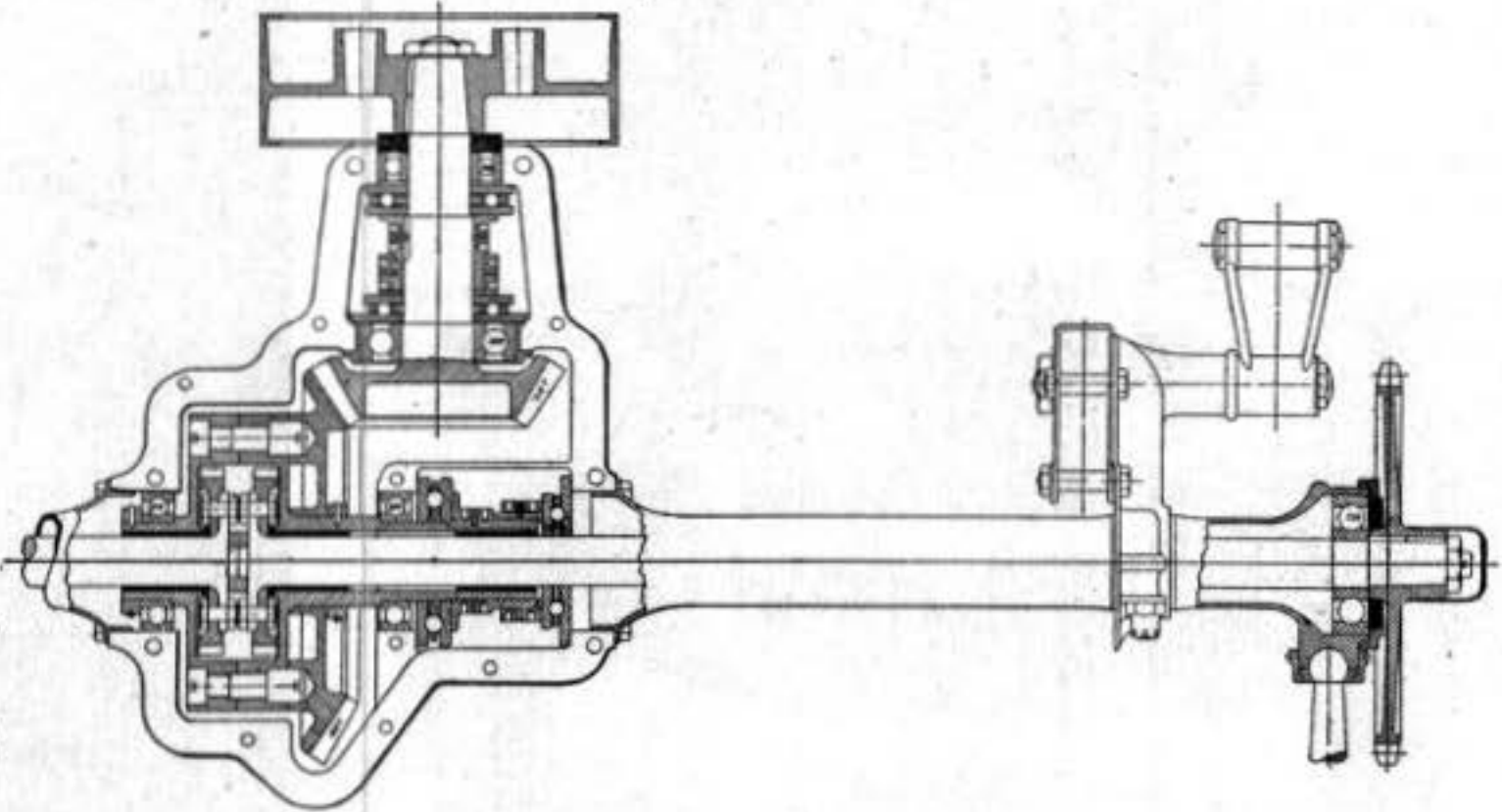

DIFFERENTIAL AND COUNTERSHAFT.

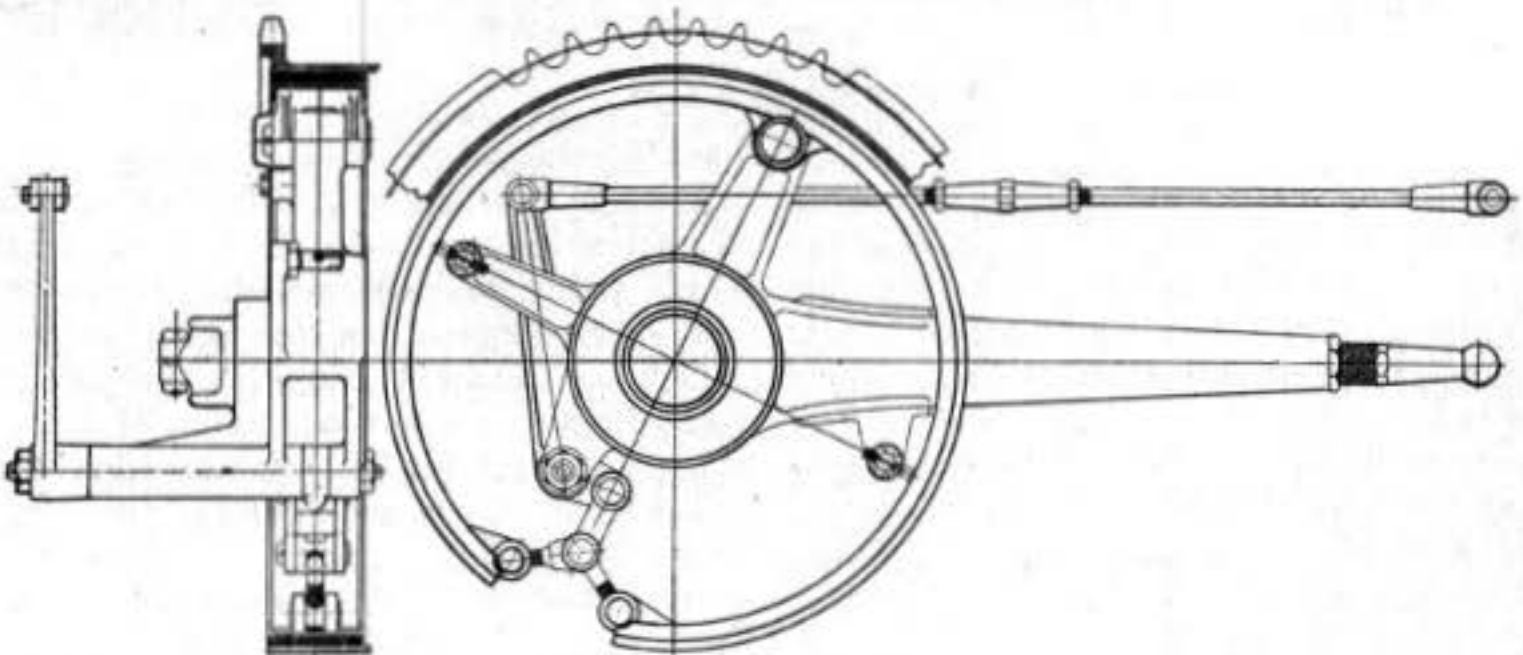

EMERGENCY BRAKE.

long characteristic of the Pope-Toledo, as will be seen from the illustration. The mud guards are also aluminum.

The equipment includes two large Parabolens searchlights, two oil lamps and a tail lamp, acetylene generator, complete equipment of tools and very large French horn. All parts of the car, except lubricator, equipment and tires, are made in the Pope factory. The management announce that on account of the time required to force and machine the exceedingly tough chrome-nickel steel their output for 1907 will be limited to 500 cars.

George Bordereaux, of Peoria, Ills., claims to have invented an improved automobile engine in which the spent gases are very rapidly discharged from the cylinder.

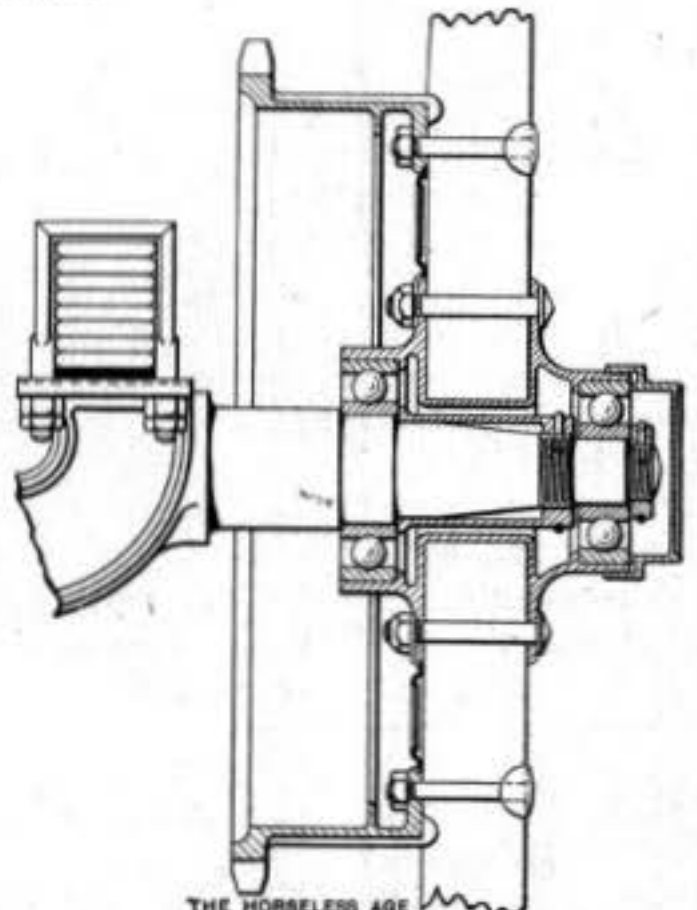

THE HORSELESS AGE

POPE-TOLEDO REAR AXLE END.